

ADS7815

16-Bit 250kHz Sampling CMOS ANALOG-to-DIGITAL CONVERTER

FEATURES

- 250kHz SAMPLING RATE
- COMPLETE WITH S/H, REF, CLOCK, ETC.
- 96dB min SFDR WITH 100kHz INPUT
- 84dB min SINAD
- $\pm 2.5V$ INPUT RANGE
- 28-LEAD SOIC

APPLICATIONS

- WIRELESS BASE STATIONS
- SPECTRUM ANALYSIS
- IMAGING SYSTEMS
- DATA ACQUISITION

DESCRIPTION

The ADS7815 is a complete 16-bit sampling analog-to-digital (A/D) converter featuring excellent AC performance and a 250kHz throughput rate. The design includes a 16-bit capacitor-based SAR A/D converter with an inherent sample and hold (S/H), a precision reference, and an internal clock. Spurious-free dynamic range with a 100kHz full-scale sine wave input is typically greater than 100dB. The $\pm 2.5V$ input range allows development of precision systems using only $\pm 5V$ supplies. The converter is available in a 28-lead SOIC package specified for operation over the industrial $-25^{\circ}C$ to $+85^{\circ}C$ temperature range.

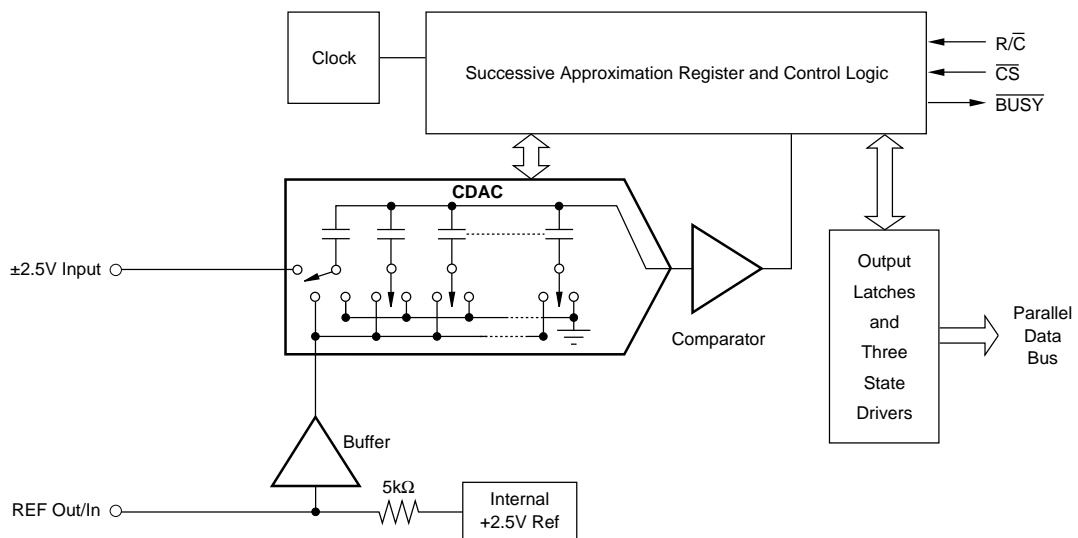

International Airport Industrial Park • Mailing Address: PO Box 11400, Tucson, AZ 85734 • Street Address: 6730 S. Tucson Blvd., Tucson, AZ 85706 • Tel: (520) 746-1111 • Twx: 910-952-1111
Internet: <http://www.burr-brown.com/> • FAXLine: (800) 548-6133 (US/Canada Only) • Cable: BBRCORP • Telex: 066-6491 • FAX: (520) 889-1510 • Immediate Product Info: (800) 548-6132

SPECIFICATIONS

At $T_A = -25^{\circ}\text{C}$ to $+85^{\circ}\text{C}$, $f_S = 250\text{kHz}$, $+V_S = +5\text{V}$, and $-V_S = -5\text{V}$, using internal reference, unless otherwise specified.

PARAMETER	CONDITIONS	ADS7815U			UNITS
		MIN	TYP	MAX	
RESOLUTION				16	Bits
ANALOG INPUT					
Voltage Range			$\pm 2.5\text{V}$		V
Impedance			100		$\text{M}\Omega$
Capacitance			30		pF
THROUGHPUT SPEED					
Conversion Cycle	Acquire and Convert			4.0	μs
Throughput Rate		250			kHz
DC ACCURACY					
Integral Linearity Error			± 4		LSB ⁽¹⁾
No Missing Codes			15		Bits
Transition Noise ⁽²⁾			0.8		LSB
Full Scale Error ⁽³⁾			± 0.1		%
Full Scale Error Drift			± 7		$\text{ppm}/^{\circ}\text{C}$
Bipolar Zero Error			± 2		mV
Bipolar Zero Error Drift			± 2		$\text{ppm}/^{\circ}\text{C}$
Power Supply Sensitivity	$+V_S \pm 5\%$, $-V_S \pm 5\%$		± 6		LSB
AC ACCURACY					
Spurious-Free Dynamic Range	$f_{IN} = 100\text{kHz}$	96	100		dB ⁽⁴⁾
Total Harmonic Distortion	$f_{IN} = 100\text{kHz}$		-98	-96	dB
Signal-to-(Noise+Distortion)	$f_{IN} = 100\text{kHz}$ -60dB Input	84		28	dB
Signal-to-Noise	$f_{IN} = 100\text{kHz}$	84			dB
Usable Bandwidth ⁽⁵⁾			1		MHz
Aperture Delay			40		ns
REFERENCE					
Internal Reference Voltage		2.45	2.5	2.55	V
Internal Reference Source Current			1		μA
External Reference Voltage Range		2.3	2.5	2.7	V
External Reference Current Drain	$V_{REF} = +2.5\text{V}$			100	μA
DIGITAL INPUTS					
Logic Levels					
V_{IL}		-0.3		+0.8	V
V_{IH}		+2.8		$+V_S + 0.3\text{V}$	V
I_{IL}				± 10	μA
I_{IH}				± 10	μA
DIGITAL OUTPUTS					
Data Format			Parallel 16 bits		
Data Coding			Binary Two's Complement		
V_{OL}	$I_{SINK} = 1.6\text{mA}$			+0.4	V
V_{OH}	$I_{SOURCE} = 200\mu\text{A}$	+4			V
Leakage Current	High-Z State, $V_{OUT} = 0\text{V}$ to V_{DIG} High-Z State			± 5	μA
Output Capacitance				15	pF
DIGITAL TIMING					
Bus Access Time				83	ns
Bus Relinquish Time				83	ns
POWER SUPPLIES					
$+V_S$		+4.75	+5	+5.25	V
$-V_S$		-5.25	-5	-4.75	V
$+I_S$			+30		mA
$-I_S$			-10		mA
Power Dissipation			200	250	mW
TEMPERATURE RANGE					
Specified Performance		-25		+85	$^{\circ}\text{C}$
Storage		-55		+125	$^{\circ}\text{C}$

NOTES: (1) LSB means Least Significant Bit. For the 16-bit, $\pm 2.5\text{V}$ input ADS7815, one LSB is $76\mu\text{V}$. (2) Typical rms noise at worst case transitions and temperatures. (3) Full scale error is the worst case of -Full Scale or +Full Scale untrimmed deviation from ideal first and last code transitions, divided by the transition voltage (not divided by the full-scale range) and includes the effect of offset error. (4) All specifications in dB are referred to a full-scale $\pm 2.5\text{V}$ input. (5) Full-Power Bandwidth defined as Full-Scale input frequency at which Signal-to-(Noise+Distortion) degrades to 60dB, or 10 bits of accuracy.

ABSOLUTE MAXIMUM RATINGS

Analog Inputs: V_{IN}	$\pm V_S$
REF	GND $-0.3V$ to $+V_S +0.3V$
CAP	Indefinite Short to GND Momentary Short to $+V_S$
$+V_S$	$7V$
$-V_S$	$-7V$
Digital Inputs	GND $-0.3V$ to $+V_S +0.3V$
Maximum Junction Temperature	$+165^{\circ}C$
Internal Power Dissipation	$825mW$
Lead Temperature (soldering, 10s)	$+300^{\circ}C$

PACKAGE/ORDERING INFORMATION

PRODUCT	PACKAGE	PACKAGE DRAWING NUMBER ⁽¹⁾	TEMPERATURE RANGE
ADS7815U	28-Pin SOIC	217	$-25^{\circ}C$ to $+85^{\circ}C$

NOTE: (1) For detailed drawing and dimension table, please see end of data sheet, or Appendix C of Burr-Brown IC Data Book.



ELECTROSTATIC DISCHARGE SENSITIVITY

This integrated circuit can be damaged by ESD. Burr-Brown recommends that all integrated circuits be handled with appropriate precautions. Failure to observe proper handling and installation procedures can cause damage.

ESD damage can range from subtle performance degradation to complete device failure. Precision integrated circuits may be more susceptible to damage because very small parametric changes could cause the device not to meet its published specifications.

The information provided herein is believed to be reliable; however, BURR-BROWN assumes no responsibility for inaccuracies or omissions. BURR-BROWN assumes no responsibility for the use of this information, and all use of such information shall be entirely at the user's own risk. Prices and specifications are subject to change without notice. No patent rights or licenses to any of the circuits described herein are implied or granted to any third party. BURR-BROWN does not authorize or warrant any BURR-BROWN product for use in life support devices and/or systems.

PIN #	NAME	DESCRIPTION
1	V _{IN}	Analog Input. Full-scale input range is ±2.5V.
2	GND	Ground.
3	REF	Reference Input/Output. Outputs internal reference of +2.5V nominal. Can also be driven by external system reference. In both cases, connect to ground with a 0.1μF ceramic capacitor in parallel with 2.2μF tantalum capacitor.
4	CAP	Reference compensation capacitor. Use a parallel combination of a 0.1μF ceramic capacitor and a 2.2μF tantalum capacitor.
5	GND	Ground.
6	D15 (MSB)	Data Bit 15. Most Significant Bit (MSB) of conversion results. Hi-Z state when \overline{CS} is HIGH, when R/\overline{C} is LOW or when a conversion is in progress.
7	D14	Data Bit 14. Hi-Z state when \overline{CS} is HIGH, when R/\overline{C} is LOW or when a conversion is in progress.
8	D13	Data Bit 13. Hi-Z state when \overline{CS} is HIGH, when R/\overline{C} is LOW or when a conversion is in progress.
9	D12	Data Bit 12. Hi-Z state when \overline{CS} is HIGH, when R/\overline{C} is LOW or when a conversion is in progress.
10	D11	Data Bit 11. Hi-Z state when \overline{CS} is HIGH, when R/\overline{C} is LOW or when a conversion is in progress.
11	D10	Data Bit 10. Hi-Z state when \overline{CS} is HIGH, when R/\overline{C} is LOW or when a conversion is in progress.
12	D9	Data Bit 9. Hi-Z state when \overline{CS} is HIGH, when R/\overline{C} is LOW or when a conversion is in progress.
13	D8	Data Bit 8. Hi-Z state when \overline{CS} is HIGH, when R/\overline{C} is LOW or when a conversion is in progress.
14	GND	Ground.
15	D7	Data Bit 7. Hi-Z state when \overline{CS} is HIGH, when R/\overline{C} is LOW or when a conversion is in progress.
16	D6	Data Bit 6. Hi-Z state when \overline{CS} is HIGH, when R/\overline{C} is LOW or when a conversion is in progress.
17	D5	Data Bit 5. Hi-Z state when \overline{CS} is HIGH, when R/\overline{C} is LOW or when a conversion is in progress.
18	D4	Data Bit 4. Hi-Z state when \overline{CS} is HIGH, when R/\overline{C} is LOW or when a conversion is in progress.
19	D3	Data Bit 3. Hi-Z state when \overline{CS} is HIGH, when R/\overline{C} is LOW or when a conversion is in progress.
20	D2	Data Bit 2. Hi-Z state when \overline{CS} is HIGH, when R/\overline{C} is LOW or when a conversion is in progress.
21	D1	Data Bit 1. Hi-Z state when \overline{CS} is HIGH, when R/\overline{C} is LOW or when a conversion is in progress.
22	D0 (LSB)	Data Bit 0. Least Significant Bit (LSB) of conversion results. Hi-Z state when \overline{CS} is HIGH, when R/\overline{C} is LOW or when a conversion is in progress.
23	-V _S	Negative supply input. Nominally -5V. Decouple to analog ground with 0.1μF ceramic and 10μF tantalum capacitors.
24	R/ \overline{C}	Read/convert input. With R/\overline{C} HIGH, \overline{CS} going LOW will enable the output data bits if a conversion is not in progress. With R/\overline{C} LOW, \overline{CS} going LOW will start a conversion if one is not already in progress.
25	\overline{CS}	Chip select. With R/\overline{C} LOW, \overline{CS} going LOW will initiate a conversion if one is not already in progress. With R/\overline{C} HIGH, \overline{CS} going LOW will enable the output data bits if a conversion is not in progress.
26	\overline{BUSY}	Busy output. Falls when a conversion is started, and remains LOW until the conversion is completed. With \overline{CS} LOW and R/\overline{C} HIGH, output data will be valid when \overline{BUSY} rises, so that the rising edge can be used to latch the data. \overline{CS} or R/\overline{C} must be HIGH within 250ns after \overline{BUSY} rises or another conversion will start without time for signal acquisition.
27	+V _S	Positive supply input. Nominally +5V. Connect directly to pin 28.
28	+V _S	Positive supply input. Nominally +5V. Connect directly to pin 27. Decouple to ground with 0.1μF ceramic and 10μF tantalum capacitors.

TABLE I. Pin Assignments.

PIN CONFIGURATION

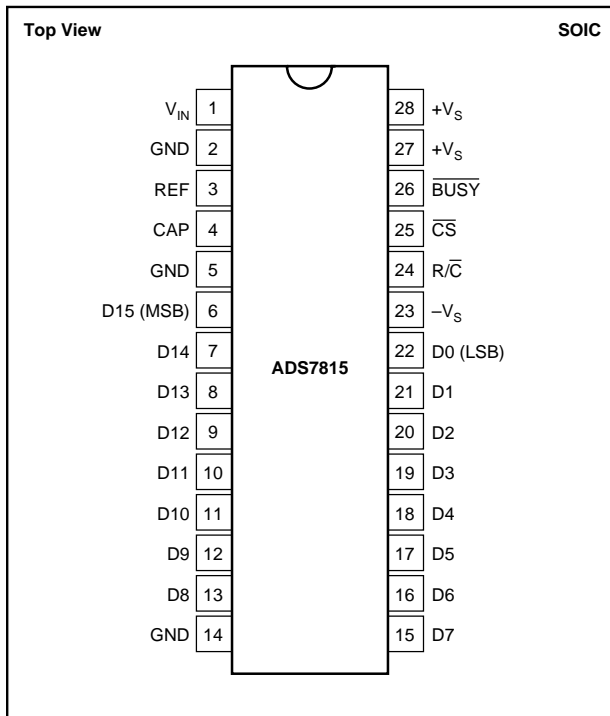

BASIC OPERATION

Figure 1 shows the recommended circuit for operation of the ADS7815. A falling edge on the convert pulse signal places the sample and hold into the hold mode and initiates a conversion. When the conversion is complete, the pins D15 through D0 become active and the result of the conversion

is placed on these outputs. In the circuit shown in Figure 1, the rising edge of BUSY latches the result into the 74HC574s.

After the conversion is complete, the ADS7815 sample and hold returns to the sample mode and begins acquiring the input signal for the next conversion. Allowing 4μs between falling edges of the convert pulse signal assures accurate acquisition of the analog input.

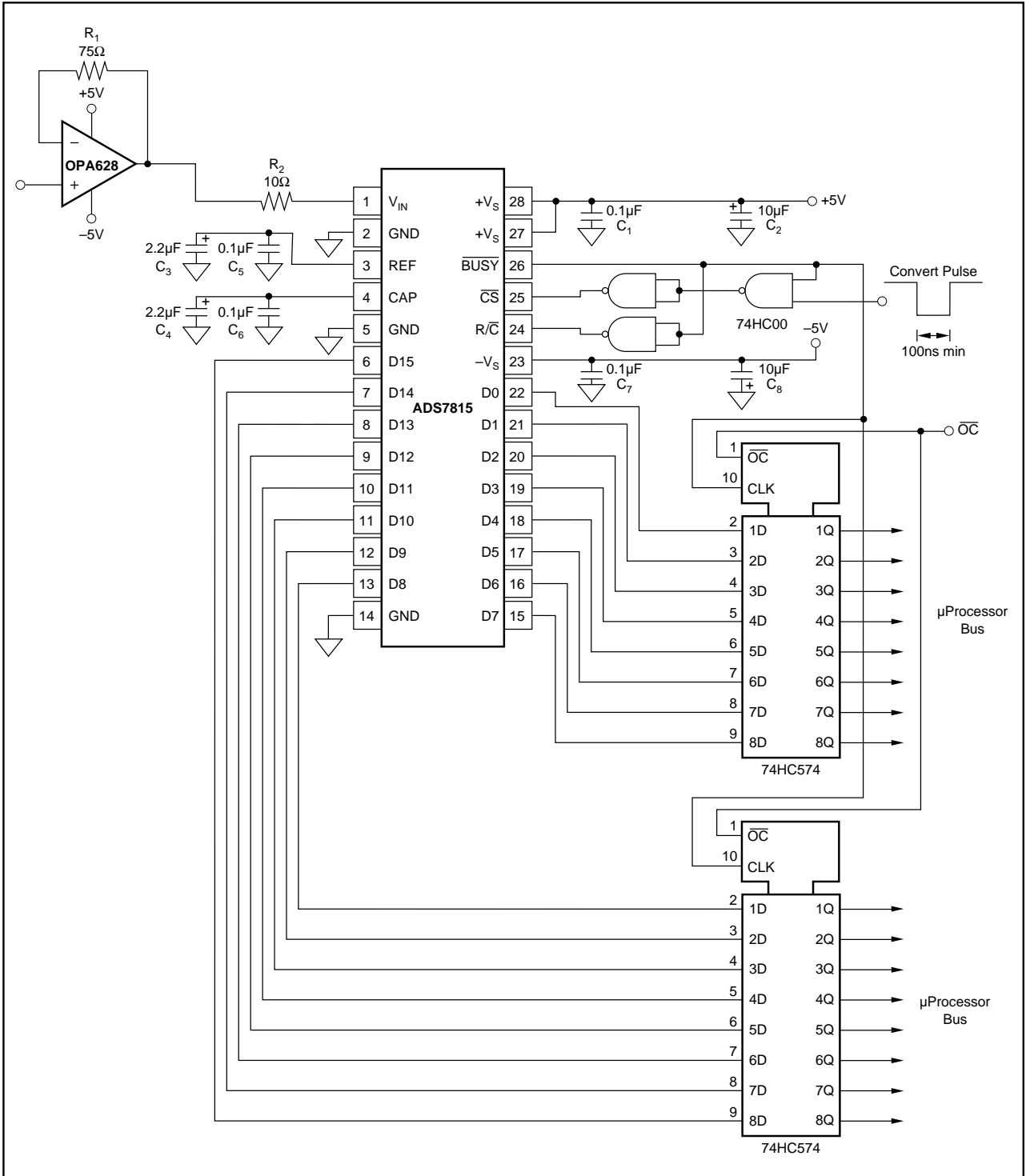

FIGURE 1. Basic Operation.

TIMING

The timing shown in Figure 2 and Table II is the recommended method of operating the ADS7815. The falling edge of \overline{CS} initiates the conversion. During the conversion, the digital outputs are tri-stated and \overline{BUSY} is LOW. Near the end of the conversion, the digital outputs become active with the most recent conversion result. After a brief delay (see time t_{11} in Figure 2 and Table II), \overline{BUSY} rises. The rising edge of \overline{BUSY} is used to latch the digital result in Figure 1.

R/C AND CS

The R/\overline{C} (read/convert) and \overline{CS} signals control the start of conversion and, when a conversion is not in progress, the status of the digital outputs D15 through D0. It is possible to start a conversion by taking \overline{CS} LOW and then taking R/\overline{C} LOW. However, this is not recommended and will result in a significant decrease in signal-to-noise ratio. This is due to

the digital outputs tri-stating while the sample and hold transitions to the hold mode. The change in digital outputs results in noise being coupled onto the hold capacitor.

If a conversion is not in progress or is just about to finish, the digital outputs will be active when R/\overline{C} is HIGH and \overline{CS} is LOW. This is shown in Figure 2 and Figure 3. It is possible to return \overline{CS} HIGH during the initial part of the conversion (as is done with R/\overline{C}) and prevent the digital outputs from becoming active. At a later time, the digital results could be read by taking \overline{CS} LOW. It is also possible to leave R/\overline{C} LOW, take \overline{CS} HIGH during the conversion, and read the results at a later time by taking R/\overline{C} HIGH and \overline{CS} LOW.

Following a conversion, if R/\overline{C} and \overline{CS} are both LOW 250ns after \overline{BUSY} rises, then a new conversion will be initiated without allowing the proper acquisition period for the sample and hold. R/\overline{C} must remain HIGH or \overline{CS} must be taken HIGH within 250ns of \overline{BUSY} rising.

SYMBOL	DESCRIPTION	MIN	TYP	MAX	UNITS
t_1	\overline{CS} to R/\overline{C} Delay			200	ns
t_2	\overline{CS} to \overline{BUSY} Delay		40		ns
t_3	Aperture Delay		40		ns
t_4	\overline{BUSY} LOW		3.3		μ s
t_5	R/\overline{C} LOW to \overline{CS} LOW	100			ns
t_6	\overline{BUSY} HIGH to \overline{CS} HIGH			250	ns
t_7	Bus Access Time		10	83	ns
t_8	Bus Relinquish Time			83	ns
t_9	Throughput Time			4	μ s
t_{10}	Conversion Time		3.3		μ s
t_{11}	Data Valid to \overline{BUSY} HIGH	25	35		ns
t_{12}	\overline{CS} to R/\overline{C} Setup Time	40			ns

TABLE II. Conversion Timing.

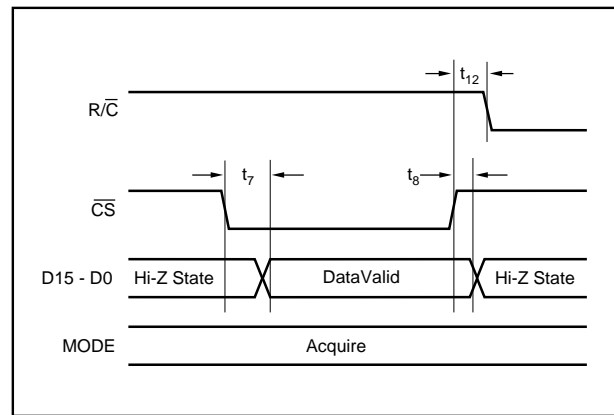

FIGURE 3. Bus Timing.

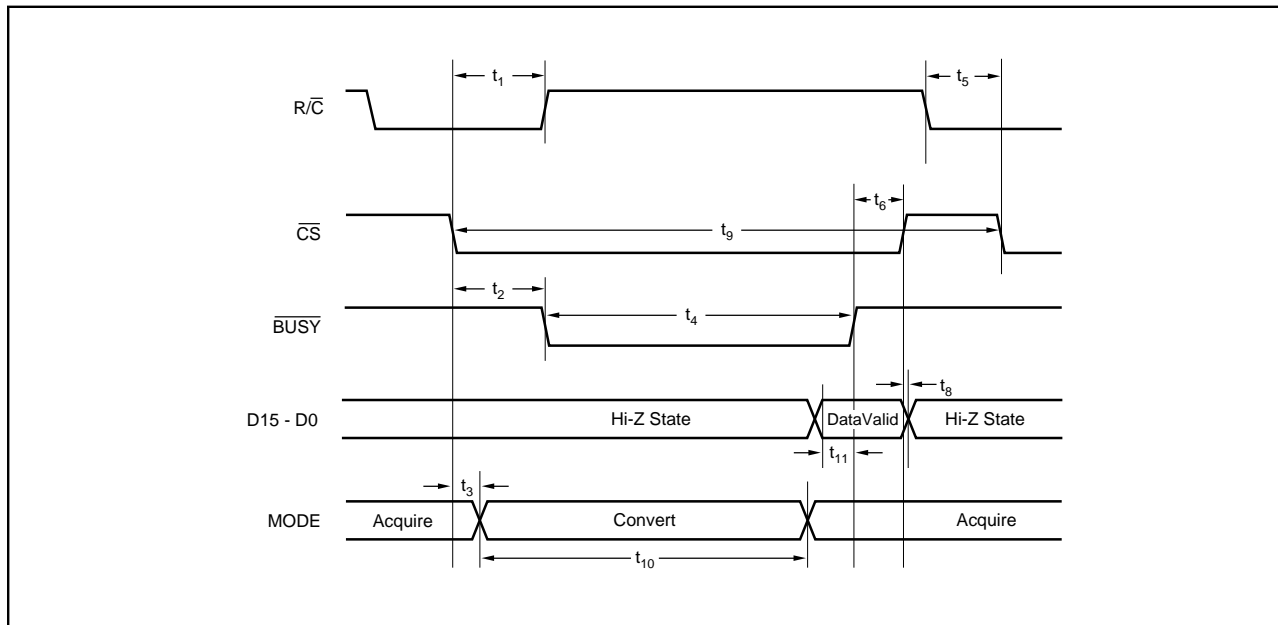

FIGURE 2. ADS7815 Timing.

$\overline{R/C}$ and \overline{CS} should remain static prior to that start of conversion and during the later part of a conversion. To start a conversion, $\overline{R/C}$ should be taken LOW at least 100ns before \overline{CS} is taken LOW. $\overline{R/C}$ and/or \overline{CS} should be taken HIGH during the early part of the conversion, preferably within 200ns of the start of the conversion. If these times are not observed, then there is risk that the transition of these digital signals may affect the conversion result.

The three NAND gates shown in Figure 1 can be used to generate $\overline{R/C}$ and \overline{CS} signals from a single negative going pulse.

BUSY

\overline{BUSY} goes LOW when a conversion is started and remains LOW throughout the conversion. Just prior to \overline{BUSY} going HIGH, the digital outputs become active with the conversion result. Time t_{11} , shown in Figure 2, should provide adequate time for the ADS7815 to drive the digital outputs to a valid logic state before \overline{BUSY} rises. As shown in Figure 1 and 2, the rising edge of \overline{BUSY} can be used to latch the digital result into an external component.

DIGITAL OUTPUT

The ADS7815's digital output is in Binary Two's Complement (BTC) format. Table III shows the relationship between the digital output word and analog input voltage under ideal conditions.

DESCRIPTION	ANALOG INPUT	DIGITAL OUTPUT	
		BINARY TWO'S COMPLEMENT	
		BINARY CODE	HEX CODE
Full Scale Range	$\pm 2.5V$		
Least Significant Bit (LSB)	$76\mu V$		
+Full Scale (2.5V - 1LSB)	2.499924V	0111 1111 1111 1111	7FFF
Midscale	0V	0000 0000 0000 0000	0000
One LSB below Midscale	$-76\mu V$	1111 1111 1111 1111	FFFF
-Full Scale	$-2.5V$	1000 0000 0000 0000	8000

Table III. Ideal Input Voltages and Output Codes.

REFERENCE

The ADS7815 can be operated with the internal 2.5V reference or an external reference. By applying an external reference to the REF pin, the internal reference is bypassed. The reference voltage at REF is buffered internally.

The voltage at the reference input sets the full-scale range of the converter. With the internal 2.5V reference, the input range is $\pm 2.5V$. Thus, the input range of the converter's analog input is simply $\pm V_{REF}$, where V_{REF} is the voltage at the reference input. Because of internal gain and offset error, the input range will not be exactly $\pm V_{REF}$. The full-scale error of the converter with an external reference will typically be 0.25% or less. The bipolar zero error will be similar

to that listed in the Specifications Table. The range for the external reference is 2.3V to 2.7V.

REF PIN

The REF pin itself should be bypassed with a 0.1 μF ceramic capacitor in parallel with a 2.2 μF tantalum capacitor. While both capacitors should be physically close to the ADS7815, it is very important that the ceramic capacitor be placed as close as possible.

The REF voltage should not be used to drive a large load or any load which is dynamic. A large load will reduce the reference voltage and the corresponding input range of the converter. A dynamic load will modulate the reference voltage and this modulation will be present in the converter's output data.

CAP PIN

The voltage on the CAP pin is the output of the reference buffer. This pin should be bypassed with a 0.1 μF ceramic capacitor in parallel with a 2.2 μF tantalum capacitor. While both capacitors should be physically close to the ADS7815, it is very important that the ceramic capacitor be placed as close as possible.

The CAP pin connects to the internal reference buffer and directly to the binary weighted capacitor array of the converter. Thus, the signal at the CAP pin has high-frequency glitches which occur at each bit decision. For this reason, the CAP voltage should not be used to provide a reference voltage for external circuitry.

LAYOUT

The layout of the ADS7815 and accompanying components will be critical for optimum performance. Use of an analog ground plane is essential. Use of +5V and -5V power planes is not critical as long as the supplies are well bypassed, and the traces connecting +5V and -5V to the power connector are not too long or too thin.

The two + V_S power pins of the ADS7815 must be tied together. The voltage source for these pins should also power the input buffer and the 74HC00 shown in Figure 1. This supply should separate from the positive +5V supply for the system's digital logic.

Three ground pins are present on the ADS7815: pin 2, pin 5, and pin 14. These should all be tied to the analog ground plane. The analog ground plane should extend underneath all analog signal conditioning components and up to the 74HC574s (or equivalent components) shown in Figure 1. The 74HC574s should not be located more than several inches from the ADS7815.

The ground for the 74HC574s should be connected to the digital ground. The analog ground plane should extend up to the 74HC574s but should be kept at least 1/4" (6mm) distant from the digital ground plane (if present). The analog and digital grounds planes should not overlap at any point.

INTERMEDIATE LATCHES

The 74HC574s shown in Figure 1 isolate the ADS7815 from digital signals on a microprocessor, digital signal processor (DSP), or microcontroller bus. This is necessary because of the precision needed within the ADS7815. The weight of a single LSB in the ADS7815 is $76\mu\text{V}$, and the comparator must be able to resolve differences in voltage to this level. External digital signals which transition during the conversion can easily couple onto the substrate and produce voltages larger than this.

In place of the 74HC574s, it might be possible to use a FIFO or similar type of memory device. For the majority of systems, it will be difficult to go directly from the ADS7815 into a microcontroller or DSP even if the ADS7815 is not connected to shared bus. The reason for this is that during a conversion, the ADS7815 outputs are tri-stated. The only chance to read the outputs are during the acquisition period. And, this is not recommended if the data will be read just prior to the converter going into the hold mode.

SIGNAL CONDITIONING

The ADS7815 input essentially consists of a switch and a capacitor. In the acquisition or sample mode, the switch is closed and the input signal drives the capacitor directly. When a conversion is started, the switch is opened capturing the input signal at that moment. This voltage is held on the capacitor for the remainder of the conversion.

While this provides for a wide bandwidth sample and hold function and results in excellent AC performance, this architecture requires a high bandwidth, precision op amp to drive the analog input. The op amp and configuration shown in Figure 1 is highly recommended. The amplifier should be placed within 1 to 2 inches (25 to 50mm) of the ADS7815, and the layout guidelines in the OPA628 data sheet should be strictly followed.

PACKAGING INFORMATION

Orderable Device	Status ⁽¹⁾	Package Type	Package Drawing	Pins	Package Qty	Eco Plan ⁽²⁾	Lead/Ball Finish	MSL Peak Temp ⁽³⁾
ADS7815U	ACTIVE	SOIC	DW	28	28	None	CU SNPB	Level-3-220C-168 HR
ADS7815U/1K	ACTIVE	SOIC	DW	28	1000	None	CU SNPB	Level-3-220C-168 HR

⁽¹⁾ The marketing status values are defined as follows:

ACTIVE: Product device recommended for new designs.

LIFEBUY: TI has announced that the device will be discontinued, and a lifetime-buy period is in effect.

NRND: Not recommended for new designs. Device is in production to support existing customers, but TI does not recommend using this part in a new design.

PREVIEW: Device has been announced but is not in production. Samples may or may not be available.

OBsolete: TI has discontinued the production of the device.

⁽²⁾ Eco Plan - May not be currently available - please check <http://www.ti.com/productcontent> for the latest availability information and additional product content details.

None: Not yet available Lead (Pb-Free).

Pb-Free (RoHS): TI's terms "Lead-Free" or "Pb-Free" mean semiconductor products that are compatible with the current RoHS requirements for all 6 substances, including the requirement that lead not exceed 0.1% by weight in homogeneous materials. Where designed to be soldered at high temperatures, TI Pb-Free products are suitable for use in specified lead-free processes.

Green (RoHS & no Sb/Br): TI defines "Green" to mean "Pb-Free" and in addition, uses package materials that do not contain halogens, including bromine (Br) or antimony (Sb) above 0.1% of total product weight.

⁽³⁾ MSL, Peak Temp. -- The Moisture Sensitivity Level rating according to the JEDEC industry standard classifications, and peak solder temperature.

Important Information and Disclaimer: The information provided on this page represents TI's knowledge and belief as of the date that it is provided. TI bases its knowledge and belief on information provided by third parties, and makes no representation or warranty as to the accuracy of such information. Efforts are underway to better integrate information from third parties. TI has taken and continues to take reasonable steps to provide representative and accurate information but may not have conducted destructive testing or chemical analysis on incoming materials and chemicals. TI and TI suppliers consider certain information to be proprietary, and thus CAS numbers and other limited information may not be available for release.

In no event shall TI's liability arising out of such information exceed the total purchase price of the TI part(s) at issue in this document sold by TI to Customer on an annual basis.

IMPORTANT NOTICE

Texas Instruments Incorporated and its subsidiaries (TI) reserve the right to make corrections, modifications, enhancements, improvements, and other changes to its products and services at any time and to discontinue any product or service without notice. Customers should obtain the latest relevant information before placing orders and should verify that such information is current and complete. All products are sold subject to TI's terms and conditions of sale supplied at the time of order acknowledgment.

TI warrants performance of its hardware products to the specifications applicable at the time of sale in accordance with TI's standard warranty. Testing and other quality control techniques are used to the extent TI deems necessary to support this warranty. Except where mandated by government requirements, testing of all parameters of each product is not necessarily performed.

TI assumes no liability for applications assistance or customer product design. Customers are responsible for their products and applications using TI components. To minimize the risks associated with customer products and applications, customers should provide adequate design and operating safeguards.

TI does not warrant or represent that any license, either express or implied, is granted under any TI patent right, copyright, mask work right, or other TI intellectual property right relating to any combination, machine, or process in which TI products or services are used. Information published by TI regarding third-party products or services does not constitute a license from TI to use such products or services or a warranty or endorsement thereof. Use of such information may require a license from a third party under the patents or other intellectual property of the third party, or a license from TI under the patents or other intellectual property of TI.

Reproduction of information in TI data books or data sheets is permissible only if reproduction is without alteration and is accompanied by all associated warranties, conditions, limitations, and notices. Reproduction of this information with alteration is an unfair and deceptive business practice. TI is not responsible or liable for such altered documentation.

Resale of TI products or services with statements different from or beyond the parameters stated by TI for that product or service voids all express and any implied warranties for the associated TI product or service and is an unfair and deceptive business practice. TI is not responsible or liable for any such statements.

Following are URLs where you can obtain information on other Texas Instruments products and application solutions:

Products		Applications	
Amplifiers	amplifier.ti.com	Audio	www.ti.com/audio
Data Converters	dataconverter.ti.com	Automotive	www.ti.com/automotive
DSP	dsp.ti.com	Broadband	www.ti.com/broadband
Interface	interface.ti.com	Digital Control	www.ti.com/digitalcontrol
Logic	logic.ti.com	Military	www.ti.com/military
Power Mgmt	power.ti.com	Optical Networking	www.ti.com/opticalnetwork
Microcontrollers	microcontroller.ti.com	Security	www.ti.com/security
		Telephony	www.ti.com/telephony
		Video & Imaging	www.ti.com/video
		Wireless	www.ti.com/wireless

Mailing Address: Texas Instruments
Post Office Box 655303 Dallas, Texas 75265